

CLEATBENDER

FOR ALL 1836 MODELS



OPERATION & MAINTENANCE MANUAL



Manual# LM1836
June 2005

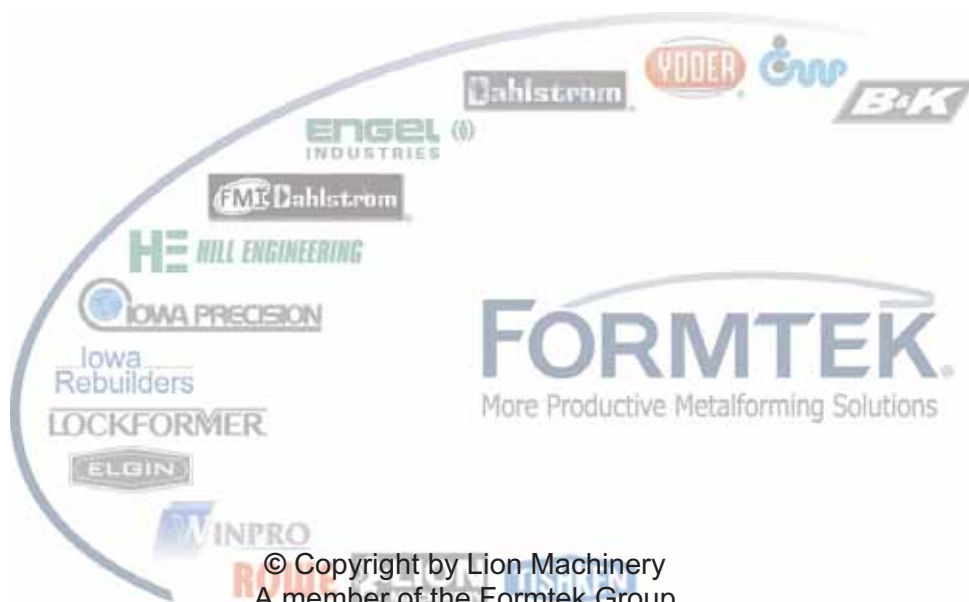

© Copyright by Lion Machinery
A member of the Formtek Group
All Rights Reserved

The information in this document has been reviewed and is believed to be completely accurate. However, no responsibility is assumed for inaccuracies. Furthermore, LION MACHINERY reserves the right to make changes to any products herein, at any time, to improve reliability, function, or design. LION MACHINERY does not assume any liabilities arising out of the application or any use of any product described herein, neither does it convey any license under its patent rights nor the rights of others.

TRADEMARK NOTICES

Lion Machinery is a registered trademark. All other brand and product names are trademarks or registered trademarks of their respective companies.

1836 Cleatbender

TABLE OF CONTENTS

TABLE OF CONTENTS

ASSEMBLY DRAWINGS *(Back of Manual)*

	<u>Section/Page</u>
1. A MESSAGE FROM LION MACHINERY	1-1
2. LOCKOUT GUIDE.....	2-1
3. SAFETY SUMMARY	3-1
A. INTRODUCTION	3-1
B. PROMOTING SAFETY	3-1
C. SAFETY PROGRAM.....	3-1
D. REFERENCE SOURCES.....	3-2
E. WARNING LABELS.....	3-2
F. WARNING MESSAGES IN THIS MANUAL.....	3-3
G. SAFETY FIRST	3-3
H. HAZARD REMINDER	3-4
4. SAFETY INSTRUCTIONS FOR ALL MODELS.....	4-1
5. SYSTEM OVERVIEW.....	5-1
A. DESCRIPTION	5-1
(1) Installation.....	5-1
(2) Sequence of Operations: (Model 1836-0).....	5-1
(3) Sequence of Operations: (Models 1836-1-3/1836-2-3/1836-3-3).....	5-2
B. TEST BEND PROCEDURES.....	5-2
(1) Test Bend Procedure (Model 1836-0).....	5-2
(2) Test Bend Procedure (Model 1836-2-3).....	5-3
(3) Test Bend Procedure (Model 1836-3-3)	5-3
C. CAM ADJUSTMENT PROCEDURES	5-4
(1) Cam Adjustment Procedure: (Model 1836-0)	5-4
(2) Cam Adjustment Procedure: (All 1836-X-3 Models)	5-5
D. TABLE SPEED ADJUSTMENT PROCEDURES: (ALL 1836 MODELS).....	5-6
E. TABLE HEIGHT ADJUSTMENT: (ALL 1836 MODELS)	5-7
(1) Table Height Adjustment Procedure	5-7
F. TABLE POSITION ADJUSTMENT: (ALL 1836 MODELS).....	5-8
G. BENDING BAR SPEED ADJUSTMENT: (ALL 1836 MODELS)	5-9
(1) Speed Adjustment.....	5-10
H. HOLD DOWN BAR ADJUSTMENT: (ALL 1836 MODELS)	5-10
(1) Adjustment Procedure	5-11

1836 Cleatbender

I. GIB ADJUSTMENT: (ALL 1836 MODELS)	5-12
J. BACK GAUGE ADJUSTMENT: (MODELS 1836-1- 3 & 1836-2-3).....	5-12
(1) Back Gauge Adjustment (1836-1-3):	5-13
(2) Back Gauge Adjustment (1836-2-3):	5-13
K. BACK GAUGE ADJUSTMENT: (MODEL 1836-3-3)	5-13
(1) Adjust 1 st Back Gauge Position:.....	5-14
(2) Adjust 2 nd Back Gauge Position:.....	5-14
(3) Adjust 3 rd Back Gauge Position:	5-14
L. CLEARING JAMS: (ALL 1836 MODELS).....	5-15
M. BEND CHART	5-16
6. MAINTENANCE INSTRUCTIONS: (ALL 1836 MODELS).....	6-1

LIST OF FIGURES

Figure 5-1 1836-0 Cam Locations	5-4
Figure 5-2 1836-X-3 Cam Locations	5-5
Figure 5-3 Table Speed Valve.....	5-6
Figure 5-4 Bending Bar Speed Valve Components	5-6
Figure 5-5 Table Height Adjustment.....	5-7
Figure 5-6 Table Position Adjustment	5-8
Figure 5-7 Table Position	5-9
Figure 5-8 Bending Bar Speed Valve.....	5-9
Figure 5-9 Bending Bar Speed Valve Components	5-10
Figure 5-10 Hold Down Bar Adjustment.....	5-11
Figure 5-11 Hold Down Bar Adjustment Components	5-11
Figure 5-12 Gib Adjustment	5-12
Figure 5-13 Back Gauge Adjustment & Switch Panel.....	5-13
Figure 5-14 Back Gauge Adjustment 1836-3-3.....	5-14
Figure 5-15 Adjusting 3 rd Back Gauge Position.....	5-15
Figure 6-1 Air Filter/Regulator/Lubricator	6-1
Figure 6-2 Lubrication Points	6-2

1836 Cleatbender

1. A MESSAGE FROM LION MACHINERY

Thank you for purchasing the LION 1836 (closed end) Cleatbender. The LION 1836 Cleatbender is manufactured with the highest quality material and workmanship.

- This machine has a capacity of 18 gauge mild steel and lighter. It cannot accept heavier material.
- The warranty on this machine is 30 days.
- Any parts found to be defective within 2 years of purchase from LION will be replaced.
- We will ship in stock warranty parts within 2 business days of receipt of order via Fed Ex ground at no charge.
- For replacement parts, call us or contact the machinery dealer from whom you purchased the machine.
- All purchase orders must be in writing (warranty and non-warranty parts).
- **PLEASE CAREFULLY READ THIS INSTRUCTION MANUAL. IT IS WRITTEN FOR OWNERS, OPERATORS AND MAINTENANCE PERSONNEL.**
- **THIS MACHINE HAS A FIXED BACK GAUGE. NO ADJUSTMENTS SHOULD BE REQUIRED WHEN IT ARRIVES. ANY ADJUSTMENTS-EVEN THOUGH OUTLINED IN THIS MANUAL MUST BE DISCUSSED WITH THE MANUFACTURER.**
- **PLEASE CALL BEFORE ATTEMPTING TO ADJUST THE MACHINE IN ANY WAY. PARTS AND LABOR WARRANTIES WILL BE NULL AND VOID IF WORK IS COMPLETED WITHOUT MANUFACTURER ASSISTANCE BY PHONE. THIS IS A SIMPLE MACHINE, ALMOST TOO SIMPLE. PLEASE CALL 314-638-0100 X-353.**
- **MAINTAIN YOUR MACHINE! KEEP THE MACHINE OUT OF AREAS WHERE SHAVINGS, GRINDING DUST, INSULATION, ETC. MAY GET INTO THE MACHINE OR WIPE DOWN THE MACHINE REGULARLY WITH A DRY RAG. READ THE MAINTENANCE INSTRUCTIONS ENCLOSED, SPECIFICALLY FOR THE FILTER REGULATOR UNIT AS IS SUPPLIED BY THE FILTER REGULATOR MANUFACTURER.**
- LION Cleatbenders are shipped, and should be stored if necessary, enclosed in shrink wrap (covered) and in crates made of wood, with lifting and shipping instructions clearly stenciled on the outside. Should the machine arrive without a crate, contact the trucking company immediately to file a claim.
- WHEN THE TIME COMES, REPAIR AND REBUILD SERVICES ARE AVAILABLE BY CONTACTING DAVE KRIVANEK AT IOWA REBUILDERS (A CERTIFIED LION REPAIR COMPANY, AT 319-364-9181. NEVER SEND YOUR MACHINE WITHOUT APPROVAL AND SCHEDULING THROUGH IOWA REBUILDERS. FREIGHT TO AND FROM IOWA REBUILDERS IS TO BE PAID THE CUSTOMER. PAYMENT MUST BE MADE IN FULL FOR WORK COMPLETED PRIOR TO RETURN SHIPPING.
- ALL WARRANTY WORK WILL STILL BE HANDLED BY LION MACHINERY.

2. LOCKOUT GUIDE

The protection of life and limb through responsible actions and adequate safeguards are the responsibility of all individuals in a workplace environment, or any environment where action or miss-action could possibly endanger the safety and wellbeing of others.

All maintenance, repair and adjustment procedures performed on this equipment shall comply with existing established **Lockout** requirements. At a minimum, these requirements must include the use of a keyed padlock or similar device utilized to physically and securely remove and isolate any power source from the equipment, preventing accidental reapplication while personnel may be in exposed circumstances, subject to possible injury or death.

These requirements must also include the **tagging** of the lockout device to notify all individuals working in the area, or anyone who could for whatever reason be in a position to possibly remove or otherwise defeat the purpose of the lockout device, as to its installation, why, and the individual responsible for its application.

Power sources include electrical, pneumatic, hydraulic, or any other hazardous energy source. This procedure shall be used to ensure that the machine is stopped and isolated from all potentially hazardous energy sources and that these energy sources are locked out before employees perform any servicing or maintenance when the unexpected energization, start-up of the machine, or the release of stored energy could cause injury.

FOR THIS UNIT (where applicable)

- **Hydraulic power** sources are provided with a lockable valve to block hydraulic pressure from the system. Where applicable, this valve shall be placed in the off position and locked in place.
- **Electrical power** sources are provided either with a male plug for connection to the electrical source, or are hardwired to the source distribution panel. When a plug is provided, the plug shall be disconnected from the source power and secured within a covering and tagged appropriately.

When hardwired to the source distribution panel, the panel shall have a manual disconnect which is lockable in the off position, or in the event of a circuit breaker, the panel will have a lockable door which will deny access to unauthorized personnel.

- **Pneumatic power** is applied to the machine through a quick disconnect fitting. This quick disconnect fitting shall be disconnected from the pneumatic power source and secured within a covering and tagged appropriately.

3. SAFETY SUMMARY

A. INTRODUCTION

Safety is everyone's business. Whether you are an equipment operator, a maintenance person, a supervisor, or business owner, you are directly responsible for the day-to-day safe operation of your LION Machinery equipment. It is your responsibility to maintain and operate this equipment in strict compliance with all applicable laws, safety regulations, and the manufacturer's recommended procedures.

B. PROMOTING SAFETY

Institute a company safety program. The formation of an organized safety program is strongly recommended. This safety program should include the formation of a safety committee to review and update company safety policies on a regular basis. Establish a firm policy on safety regulations in the work place. Publish these objectives, spelling out each employee's responsibilities. **Make certain that each employee knows what is expected of them.**

C. SAFETY PROGRAM

The following steps are suggestions that a company developing, or expanding, a comprehensive safety program should consider:

1. LION Machinery carefully designed safeguards into their products in order to minimize hazards. However, the manner in which equipment is incorporated into a manufacturing process may inadvertently create a hazard or otherwise defeat built-in safeguards. Closely examine the operation of your company's processing equipment. Take notice of potential hazards. Install guards or take other appropriate action to eliminate hazard risks.
2. Make certain equipment operators and maintenance personnel are properly trained.
3. Setup a program of daily, weekly, and monthly machinery inspection. Make a check list. Keep a historical record of all maintenance work, repairs, and adjustments.
4. Frequently evaluate safety guards and devices during actual production runs. **Correct any unsafe practice or situation immediately.**
5. Provide personal protective equipment, such as safety glasses with side shields, safety helmets, tongs, gloves, hand pads, spats, and protective sleeves, as required to suit the operation.
6. Organize a company safety committee. Schedule periodic meetings on a regular basis to review and update all safety policies.
7. Establish a firm policy on safety regulations in the work place. Publish these objectives, spelling out each employees responsibilities. **Make certain that each employee knows what is expected of them.**
8. Investigate all accidents and close calls. Take immediate action to prevent a recurrence of the incident. Keep records of the investigation and the corrective measures taken.
9. Post a list of names, addresses, and phone numbers of physicians and others who are to be called in emergency situations.

1836 Cleatbender

D. REFERENCE SOURCES

Questions concerning specific hazards or safeguarding of equipment may be addressed to the equipment manufacturer. For additional information, refer to the sources listed here:

American National Standards Institute (ANSI)

ANSI B11.18, "Machinery and Machine Systems for the Processing of Coiled Strip, Sheet and Plate - Safety Requirements for Construction, Care and Use." **ANSI B11.4**, "Shears: Safety Requirements for Construction, Care and Use." **ANSI B11.14**, "Coil-Slitting Machines/Systems Safety Requirements for Construction, Care and Use." **ANSI B11.18**, "Machinery and Machine Systems for the Processing of Coiled Strip, Sheet and Plate - Safety Requirements for Construction, Care and Use."

National Fire Protection Association (NFPA)

NFPA 79, "Electrical Standards for Industrial Machinery."

European Union

"Directives on Safety of Machinery" and "CE Marking"

E. WARNING LABELS

Warning and safety related informational labels were placed on the Lion Machinery equipment at strategic points. It is important that these labels not be removed, covered, hidden, or defaced. The purpose of these labels is to alert personnel to potential personal injury hazards or *other* direct or indirect safety concerns.

- **DANGER** indicates an imminently hazardous situation which avoided, will result in death or serious injury.
- **WARNING** indicates a potentially hazardous situation which avoided, could result in minor or serious injury.
- **CAUTION** indicates a potentially hazardous situation which, avoided, may result in minor or moderate injury.
- **NOTICE** indicates a company policy that relates directly or indirectly to the safety of personnel or protection of property.

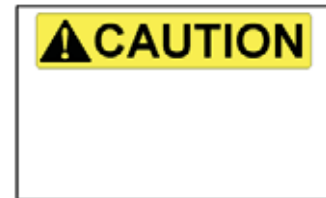

1836 Cleatbender

It is important that the meaning of a safety sign be clearly understood by those who may come in contact with the hazard. To increase the understanding of a safety sign's components, the ANSI Z535 committee encourages safety sign manufacturers and owners of facilities to publish and exhibit the following (*above*) information on safety posters, safety bulletins or the like. Doing so will assist in the objective of achieving a national uniform system for the recognition of potential personal injury hazards and accident prevention." - ANSI Z535.2, Annex A1

F. WARNING MESSAGES IN THIS MANUAL

Throughout this manual various **▲DANGER**, **▲WARNING**, **▲CAUTION**, and safety related **▲NOTICE** appear. The intent is to alert operator and maintenance personnel to potential hazards. In addition, *important* operation and maintenance details are emphasized with the **▲NOTE** heading.

G. SAFETY FIRST

The equipment in this line was designed and manufactured for a specific task. **DO NOT** use the equipment for any other function or to process material that is beyond the equipment's design specifications. Modifications or additions to this equipment line should not be made without first consulting Lion Machinery. Replacement and maintenance parts should be equal to original equipment. Use of other parts may result in unsafe operating conditions. If there is a question as to the suitability of a part, Lion Machinery should be consulted.

In general, every piece of equipment must be treated as dangerous. While operating or maintaining this equipment, each person must be aware of their own safety as well as the safety of all others around the line.

Metal Strips

The metal strip may have sharp or ragged edges. The strip is under tension and is subject to abrupt tension changes. This can result in strip breakage with the ends flying without warning. Stay clear of the strip whenever possible. When it is necessary to approach or handle the strip, use extreme caution. Use protective devices such as tongs, gloves, eye protection, and wrist guards as required for safety. The strip presents many pinch hazards with the machinery. Stay clear of these. Never step on or over strip in the line.

Machinery

Never reach into any piece of machinery which is operating or which is capable of operation. Loose clothing or jewelry should be kept clear of machinery at all times. When working on one piece of equipment, be aware of hazards of surrounding equipment. Any item inserted into a machine may be thrown or may cause a dangerous malfunction or breakage.

Safe Guards

No equipment should be operated unless the safe guards or devices supplied with the product are securely in place and properly adjusted.

▲WARNING

LION has conducted hazard evaluation and risk analysis studies for their products. Safe guards installed on the equipment are there for a reason. BEFORE EQUIPMENT IS PLACED INTO SERVICE, ALL SAFE GUARDS OR DEVICES MUST BE IN PLACE AND PROPERLY ADJUSTED.

1836 Cleatbender

Maintenance

Before performing any maintenance on a piece of equipment, insure that all power is locked off in accordance with your company's lockout/tagout policy. Be sure that all movable members (*such as rolls, arms, tables, etc.*) are securely blocked from inadvertent motion which might be hazardous. Treat all electrical lines as being live and all piping as being under high pressure. Insure that all items are properly reassembled before placing them into operation. *Before equipment is returned to service, ALL safe guards or devices MUST BE in place and properly adjusted.*

▲ NOTICE

Before doing any WELDING ON EQUIPMENT, the following precautions must be taken to insure against damage:

- 1) All power is removed from system.
- 2) The weld ground is connected to the closest possible location on the unit where the welding is being performed.
- 3) All encoders, sense eyes, and controls should be electronically disconnected if at all possible to avoid possible damage.

Traffic Around Equipment

Care should be taken at all times in moving around the equipment, whether on foot or in a vehicle. Changes in floor elevation, machine bases and debris around the equipment are trip hazards. Take care that personnel are not trapped between vehicles and equipment.

▲ DANGER

Do not attempt to walk or climb on any machine while in operation. Failure to observe this warning may result in death or serious injury.

H. HAZARD REMINDER

Use the following HAZARD REMINDER sheet to reinforce awareness of the hazards associated with HVAC related equipment. This reminder can be a useful supplement to your company's safety program. *LION suggests the following steps:*

1. SHOW each individual the HAZARD REMINDER sheet and explain each category of hazard.
2. POINT OUT EXAMPLES of each type of hazard on the actual equipment the individual operates or works around.
3. EXPLAIN HOW TO AVOID HAZARDS in the individuals work environment.
4. GIVE a copy of the HAZARD REMINDER sheet to each individual.

Safety is everyone's business!

1836 Cleatbender

THINK SAFETY FIRST

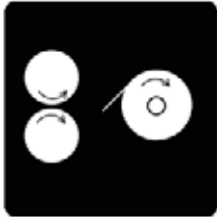

NIP POINT

WHEN ONE OBJECT ROTATES NEAR ANOTHER, IT CAN PULL YOU IN *and* CRUSH YOU

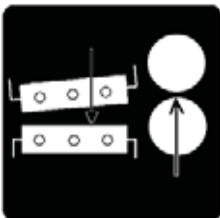

PINCH POINT

WHEN ONE OBJECT MOVES CLOSER TO ANOTHER, IT CAN CUT *or* PINCH YOU.



MOVING EQUIPMENT *and* COILS

CAN KNOCK YOU OFF BALANCE *or* CRUSH YOU



STRIP EDGES *and* ENDS

CAN CUT *or* STRIKE YOU.



ELECTRICAL *and* FLUID SYSTEMS

CAN SHOCK *and* BURN YOU *and* CAN EXPLODE.



CLIMBING ON MACHINES

CAN MAKE YOU FALL - *MAYBE INTO ONE OF THE HAZARDS ABOVE.*

1836 Cleatbender

4. Safety Instructions for all models

This machine should only be operated with all guards in place! Review your machine to understand the location of all guards listed below.

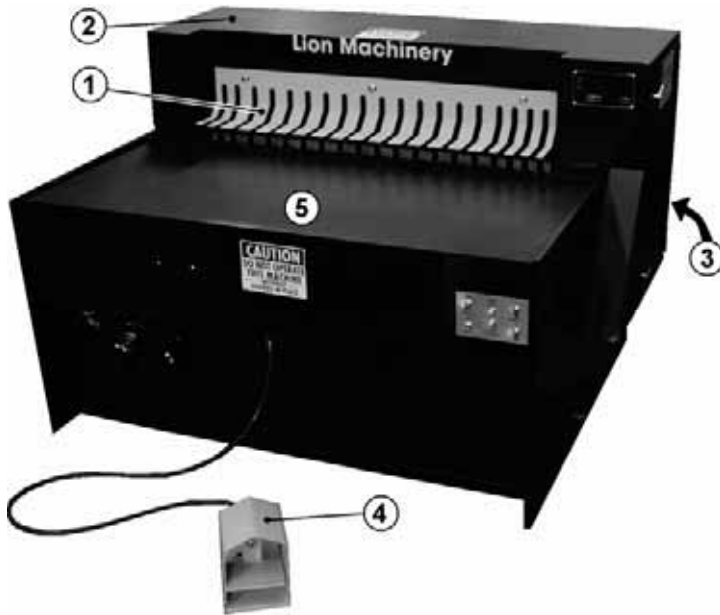

1	Finger Guard
2	Top Cover
3	Back Panel (Behind Unit)
4	Foot Pedal Guard
5	Machine Table Top

⚠ WARNING:
NEVER ATTEMPT TO PLACE YOUR HANDS OR FINGERS UNDER THE FINGER GUARD!
Keep finger guard at its lowest position, as close to the table as possible to allow ONLY material under it!

⚠ WARNING:
DO NOT REMOVE ANY GUARDS WHEN MACHINE IS OPERATING. DO NOT REMOVE ANY GUARD WHEN AIR IS SUPPLIED TO THE MACHINE. IF GUARDS HAVE BEEN REMOVED FOR MAINTENANCE, BEFORE TESTING AND/OR OPERATING THE MACHINE RETURN GUARDS TO THEIR PROPER POSITION.

When performing any maintenance or adjustment of the machine observe the following precautions:

1. Remove the air supply line to the machine.
2. Depress foot pedal several times to release air pressure in the table and bend cylinders.
3. Depress small valves on the front of the machine until no airflow is heard.
4. Be sure all guards are properly in place before reconnecting the airline.
5. Loose objects and tools should not be rested anywhere on the machine. These items may enter the bending area and cause damage for which LION is NOT responsible.

1836 Cleatbender

SYSTEM OVERVIEW

5. SYSTEM OVERVIEW

A. DESCRIPTION

The LION 1836 Cleatbenders offers an economical way of producing a variety of seams, locks, cleats and bends. The four models available offer a wide range of back gauge positions, along with a variety of bend angles.

These machines are easy to setup and minimal maintenance is required. The maximum capacity of the 1836 series is 18 gauge mild steel, with a bend length of 3 to 36 inches. The bend width range is 7/16 inches to 1 inch.

(1) Installation

When your LION 1836 Cleatbender arrives from the factory, ensure the following tasks are completed before attempting to use the machine. In addition, ensure ALL operators have read and understand this manual.

1. Remove the machine from the crate.
2. After moving it to the location where it is to be used, check to ensure the machine is sitting solid and level on the floor.
3. If the machine rocks, place shims under the machine feet until the machine is solid and level.
4. Install anchors to the floor to keep the machine from "walking" during use.
5. Run a 1/2 inch air main to the machine and connect it to the filter, oiler and pressure regulator assembly on the front panel of the machine.
6. Fill the oiler with pneumatic tool oil. (Available at most hardware stores)
7. Turn on the air supply and using the pressure regulator on the front panel, set the air pressure to 90psi.
8. Cycle the machine by depressing the foot pedal momentarily. Adjust oil flow using the knob on top of the lubricator to give one drop of oil every ten machine cycles.

Once the machine is properly secured to the floor and air supply is established you are ready to begin the test bend procedure. This procedure will ensure your LION Cleatbender is ready for operation.

(2) Sequence of Operations: (Model 1836-0)

1. Insert metal until it contacts the back gage fingers.
2. Momentarily depress foot pedal to start the bending cycle.
3. Table bar slides forward and contacts limit valve under table.
4. Limit valve starts bending bar in motion.
5. Bending bar swings down around fixed back gage fingers.
6. As bending progresses the #1 cam on the right side of the machine depresses the limit valve.

1836 Cleatbender

7. Limit valve causes table bar to retract.
8. Bending continues until angle cam depresses front limit valve.
9. Limit valve reverses bending bar motion.
10. Bending bar returns to upright position.
11. Formed part is removed from the machine.

(3) Sequence of Operations: (Models 1836-1-3/1836-2-3/1836-3-3)

1. Insert metal until it contacts the back gauge fingers.
2. Momentarily depress foot pedal to start the bending cycle.
3. Table bar slides forward and contacts limit valve under table.
4. Limit valve starts bending bar in motion.
5. Bending bar swings down.
6. As bending progresses the #1 cam on the right side of the machine depresses the limit valve.
7. Limit valve causes table bar to retract.
8. Bending continues until #2, #3 or #4 cam (depending on alternate bend angle selected) contacts limit valve.
9. Limit valve reverses bending bar motion.
10. Bending bar returns to upright position.
11. Gauge swings up to start position.
12. Formed part is removed from the machine.

B. TEST BEND PROCEDURES

To ensure your machine is forming the desired seams, locks, cleats and bends, you need to complete the following test bend procedures for your specific model.

(1) Test Bend Procedure (Model 1836-0)

1. Place a piece of metal from 3 to 36 inches wide (depending on your model's bend length) on the table and slide it into the machine until it contacts the rear gage fingers.
2. Depress the foot pedal momentarily to start the bend cycle.

The table bar beneath the table should slide forward and lock the work in place. Bending will begin when the table bar is in the full forward position. At the end of the bending cycle the bending bar will return to the upright position and the piece can be removed from the machine.

3. Check the drive cleat edge you have made for width, tightness, and angle of bend.

If everything looks good you may use the machine without making any adjustments.

If adjustments are necessary see the appropriate section on adjustments in this manual before making any changes.

1836 Cleatbender

(2) Test Bend Procedure (Model 1836-2-3)

1. Place a piece of metal from 3 to 36 inches wide on the table and slide it into the machine until it contacts the rear gage.

2. Depress the foot pedal and immediately remove your foot from the pedal.

The table bar beneath the table should slide forward and lock the work in place. Bending will begin when the table bar is in the full forward position. At the end of the bending cycle the bending bar will return to the upright position and the piece can be removed from the machine.

3. Check the drive cleat edge you have made for width, tightness, and angle of bend.

▲NOTE:

The Model 1836-x-2 bends a drive cleat edge or an alternate bend in the same way the 1836-1-3 operates.

The operator may pre-set the back gauge for a second width of bend. See the instructions on setting the back gauge.

The second bend width is selected by moving the toggle switch on the switch panel to the up position. If the handle is down the bend will be 7/16 to 1/2 inch wide. If the handle is up the bend will be something greater than the forward setting. Most shops set the second width at 3/4 or 1 inch. The operator can then bend a 1/2-inch hem or 1/2 inch angle bend and by moving the back gauge shift lever can also make a 1 inch wide hem or angle bend.

(3) Test Bend Procedure (Model 1836-3-3)

1. Place a piece of metal from 3 to 36 inches wide on the table and slide it into the machine until it contacts the rear gage.

2. Depress the foot pedal and immediately remove your foot from the pedal.

The table bar beneath the table should slide forward and lock the work in place. Bending will begin when the table bar is in the full forward position. At the end of the bending cycle the bending bar will return to the upright position and the piece can be removed from the machine.

3. Check the drive cleat edge you have made for width, tightness, and angle of bend.

4. The 2nd bend width is selected by moving the toggle switch on the switch panel to the up position. If the handle is down the bend will be 7/16 to 1/2 inch wide. If the handle is up the bend will be something greater than the forward setting. Most shops set the second width at 3/4 or 1 inch. The operator can then bend a 1/2-inch hem or 1/2 inch angle bend and by moving the back gauge shift lever can also make a 1 inch wide hem or angle bend.

5. The 3rd bend width is selected by moving both toggle switches to the “on” or “up” position.

If this is your first time adjusting the machine or you have not adjusted the machine in some time, PLEASE CALL US at (314) 638-0100 X-353 for assistance. The person actually doing the adjustments should call as message relay for adjustments has not been effective in the past. We must talk to the person doing the adjustments!

1836 Cleatbender

▲WARRANTY NOTE:

If adjustments are made that are not listed above and/or instructed by the factory, the machine warranty may be null and void. Call for assistance!

C. CAM ADJUSTMENT PROCEDURES

Each model of Cleatbender utilizes anywhere from two to three cams which are used to control the table bar during the bending cycle and when the bar returns to its "home" position after the bend.

(1) Cam Adjustment Procedure: (Model 1836-0)

The control cams for Model 1836-0 are mounted inside the door on the right side of the machine. The #1 cam (Item **A**) controls the point at which the table bar is pulled back during the bending cycle. The table bar should pull back just before the bending bar would pinch the metal and table and lock up the machine.

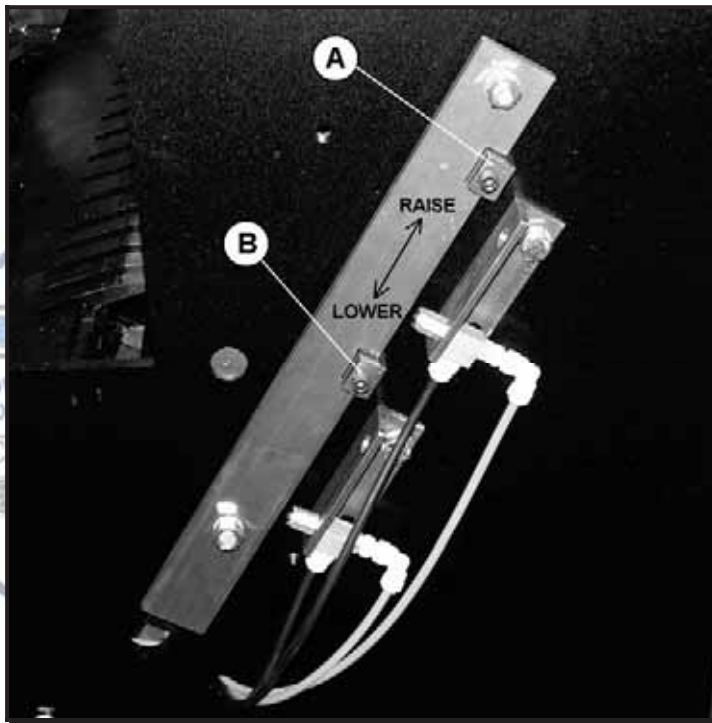

Figure 5-1 1836-0 Cam Locations

(a) Adjusting Cam #1

- If the bending bar seems to catch the table bar and delays the motion of the table bar; lower #1 cam (Item **A**).
- If the table bar pulls back too quickly during the bending cycle, incomplete bends will be made.
- If the bends do not finish, raise #1 cam (Item **A**) up slightly from the factory set position.

1836 Cleatbender

(b) Adjusting Cam #2

- a. The #2 cam (Item B) reverses the bending action.
- b. If the machine makes a complete bend and stops with the bending bar locked against the hem; lower the #2 cam (Item B) to reverse the bending action sooner.

(2) Cam Adjustment Procedure: (All 1836-X-3 Models)

The control cams for Model 1836-X-3 models are mounted inside the door on the right side of the machine. Location of the cams determines bend profiles and the sequence of operation.

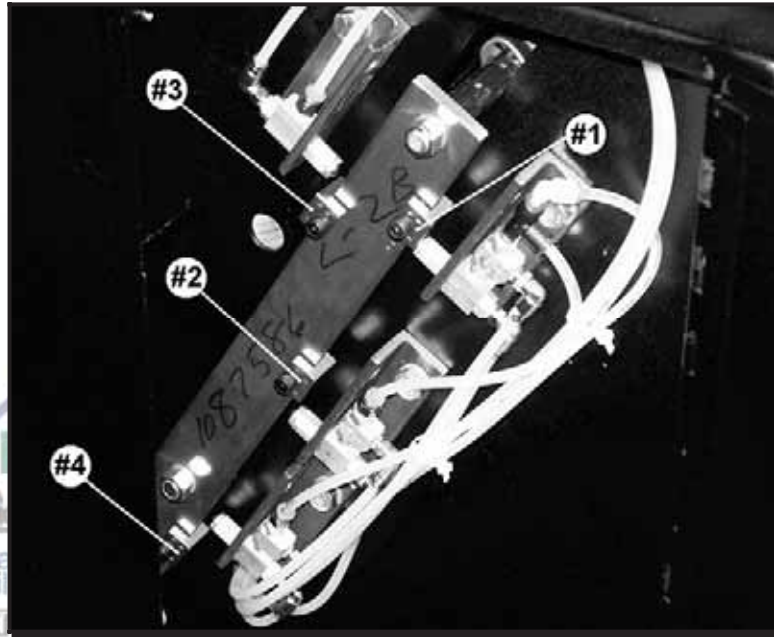

Figure 5-2 1836-X-3 Cam Locations

The #1 cam controls the point at which the table bar is pulled back during the bending cycle. The table bar should pull back just before the bending bar would pinch the metal and table and lock up the machine.

- If the bending bar seems to catch the table bar and delays the motion of the table bar; move the #1 cam down slightly from the factory set position.
- If the table bar pulls back too quickly during the bending cycle, incomplete bends will be made.
- If the bends do not finish, move the #1 cam up slightly from the factory set position.

The #2 cam reverses the bending action.

- If the machine makes a complete bend and stops with the bending bar locked against the hem' move the #2 down to reverse the bending action sooner.

The #3 and #4 cams control the alternate bend angle when the toggle on the front panel is in the up position.

- Moving the #3 or #4 cam down the bar causes it to contact the limit valve earlier in the cycle and results in a smaller angle of bend.

1836 Cleatbender

- Moving the cam up the bar delays the contact with the limit valve until later in the cycle and causes a greater angle of bend.

D. TABLE SPEED ADJUSTMENT PROCEDURES: (ALL 1836 MODELS)

The speed of movement of the table is controlled by a control valve located on the exhaust ports of the table valve located just left of center under the table of the machine.

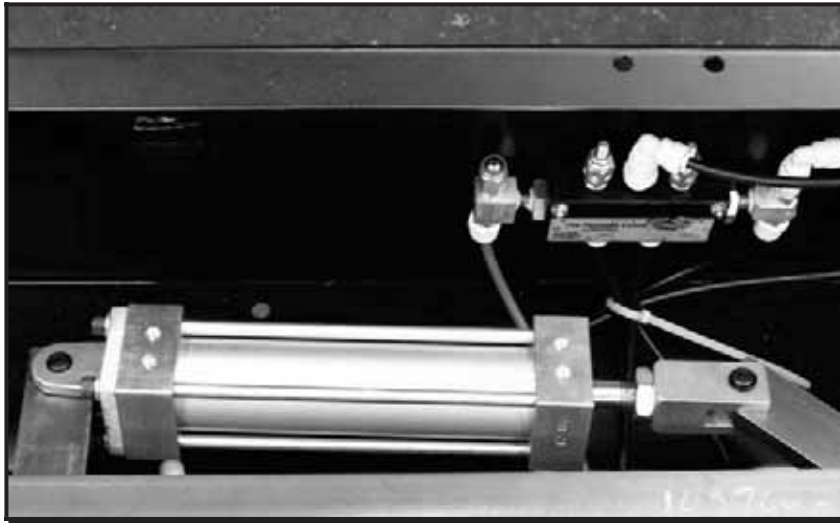

Figure 5-3 Table Speed Valve

One speed control controls the speed at which the table moves forward. The other speed control controls the speed at which the table retracts.

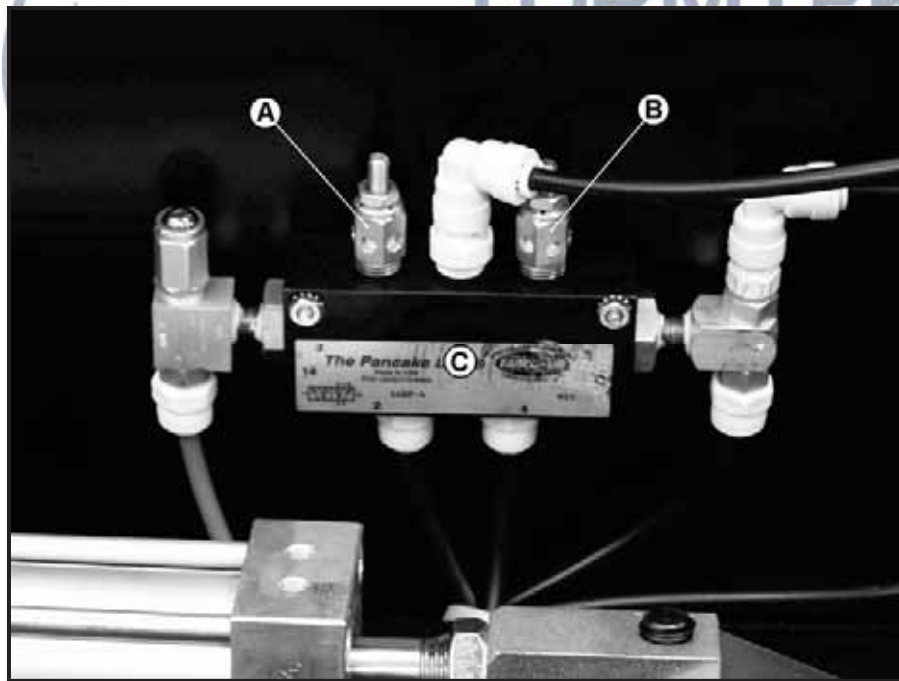

Figure 5-4 Bending Bar Speed Valve Components

1836 Cleatbender

1. To increase the table speed, loosen the locknut on adjustment screw **A**, and turn the screw counterclockwise. This opens the speed control and allows the table to move faster. Remember to tighten the locknut after the adjustment has been made.
2. To slow table motion turn the screw clockwise.
3. The speed at which the table advances at the beginning of the cycle is not critical. The table should move forward smoothly and not “bang.”
4. The speed at which the table is retracted during the bending cycle is very critical and is related to the speed of the bending bar. The table must move back before it is pinched by the bending bar.
5. The #1 cam determines the point in the bending cycle when the table starts to move.
6. The speed control allows speed control of the table to ensure that the table will not be pinched by the bending bar.

E. TABLE HEIGHT ADJUSTMENT: (ALL 1836 MODELS)

The table height was factory set with a single thickness of 18 gauge metal inserted between the table and the hold down bar.

⚠ CAUTION:

The machine will jam if the clearance between the table bar and hold down bar is less than the thickness of the metal to be bent.

(1) Table Height Adjustment Procedure

If for some reason the table height will not accommodate your material thickness, please follow the recommended step by step procedure below.

⚠ NOTICE:

The table height MUST BE raised for bending of lighter gauge metals.

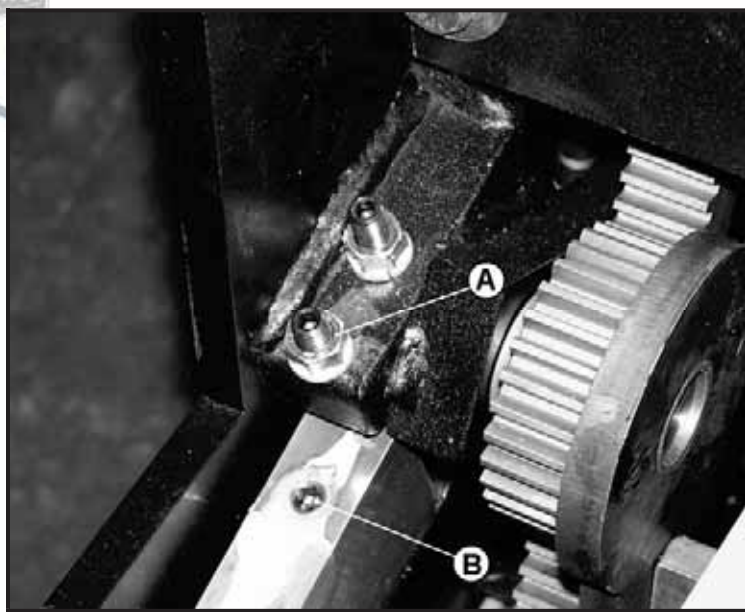

Figure 5-5 Table Height Adjustment

1836 Cleatbender

- ✓ To raise the table:
 1. Loosen the lock nut on adjusting screw **A**.
 2. Turn adjusting screw counter clockwise to loosen.
 3. Tighten adjusting screw **B** to raise the table guide.
 4. Use a piece of metal of the same thickness to be bent as a feeler gauge between the table bar and the hold down bar.
 5. Once the proper clearance is set, tighten adjusting screw **A** and retighten the lock nut.
- ✓ To lower the table:
 1. Loosen adjusting screw **B** by turning counter clockwise.
 2. Loosen locking nut on adjusting screw **A**.
 3. Turn adjusting screw **A** clockwise to lower the table.
 4. Once the proper clearance is set, tighten the lock nut on adjusting screw **A**.

F. TABLE POSITION ADJUSTMENT: (ALL 1836 MODELS)

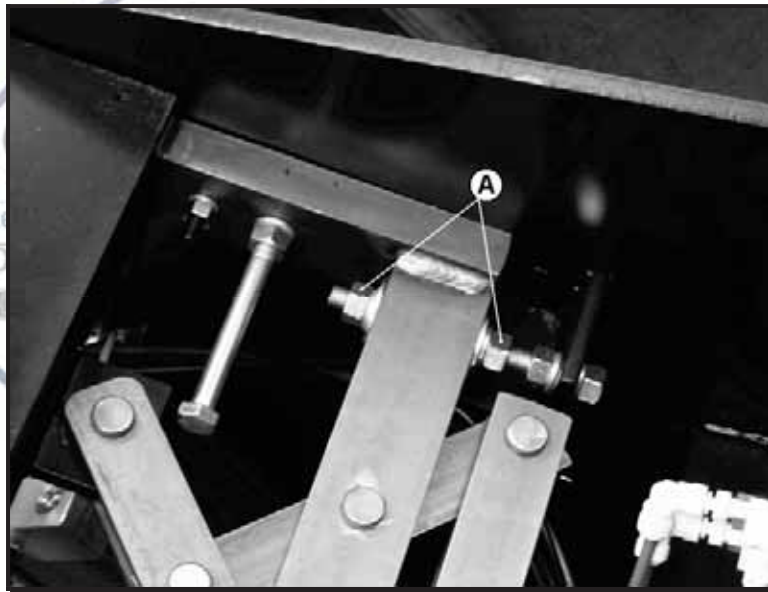

Figure 5-6 Table Position Adjustment

1. The table bar position is adjusted using the adjustment nuts (**A**) located under the main table.
2. The entire table bar assembly is moved by using the hex nuts located at the welded angle mounts on the sides of the machine.
3. To adjust the table position, loosen the nut in the direction of adjustment.
4. With the opposite nut, rotate clockwise and adjust as needed.
5. Secure both nuts.

1836 Cleatbender

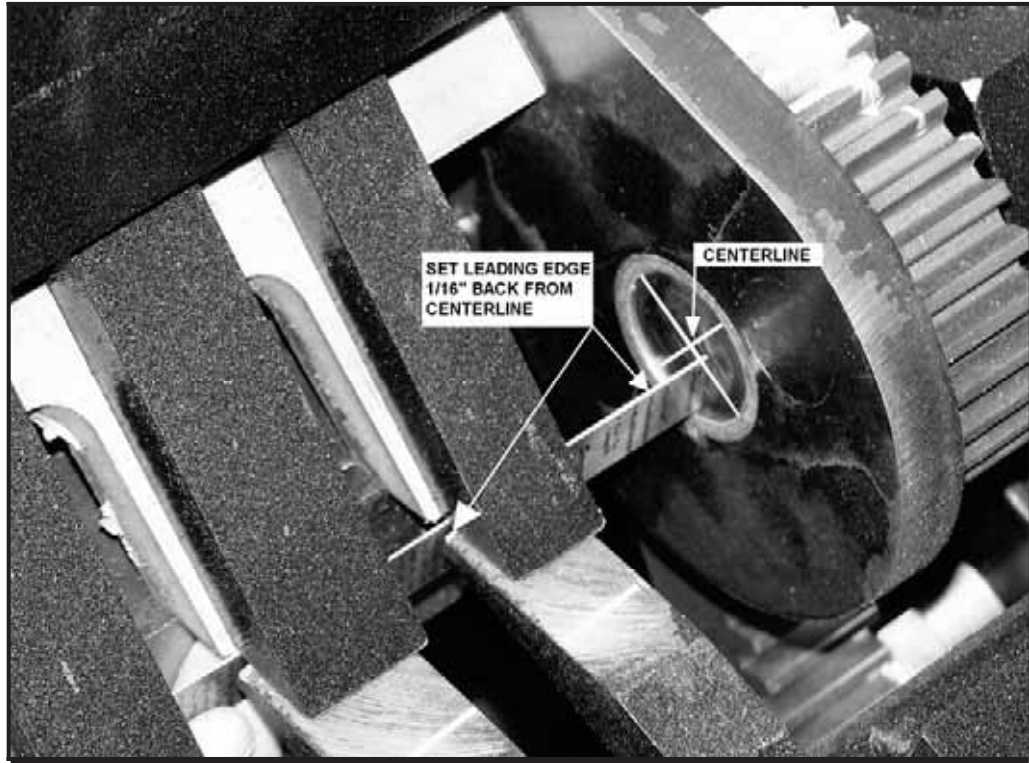

Figure 5-7 Table Position

6. The front edge of the table should be 1/16 inch short of the centerline of rotation when the table is in the forward position. This dimension may be determined from the center mark on the bearing pins on each side of the machine.

G. BENDING BAR SPEED ADJUSTMENT: (ALL 1836 MODELS)

The Bending Bar speed is critical during the forward movement or bending cycle. The speed at which the bar returns is not as critical. The metal may be removed as soon as the bending bar reverses. The valve used to control these functions is located inside the front panel of the table.

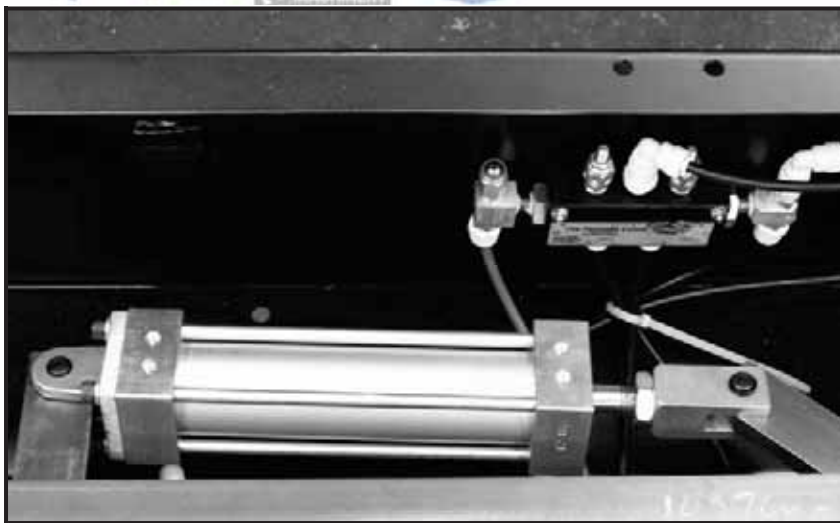

Figure 5-8 Bending Bar Speed Valve

1836 Cleatbender

(1) Speed Adjustment

1. To increase the bending bar speed, loosen the locknut and turn the screw counterclockwise, to slow the bending bar speed, turn the screw clockwise. Remember to tighten the locknut after the adjustment has been made.

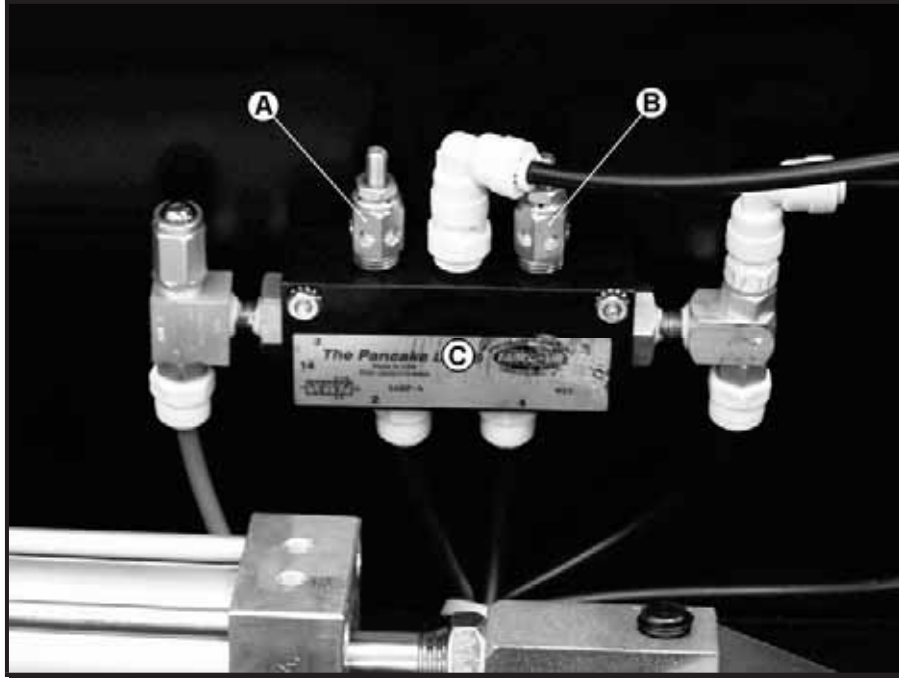

Figure 5-9 Bending Bar Speed Valve Components

2. The speed at which the bending bar advances determines the total length of the bending cycle.
 - a) The total bend cycle time should take three to four seconds.
 - b) The bending portion of the cycle should only take one to one and a half seconds.
3. The speed at which the bending bar returns to the start position is not critical.

▲ NOTICE

Excessive return speed will cause premature wear and tear on the components.

H. HOLD DOWN BAR ADJUSTMENT: (ALL 1836 MODELS)

The bottom surface of the hold down bar (Item C) and the bottom surface of the bending bar (Item A) should be flush * (see below). The Rear Gauge Bars (Item B) shown in the photo are only present on the 1836-0 model. To re-align the Hold Down Bar and the Bending Bar, follow the recommended procedure.

1836 Cleatbender

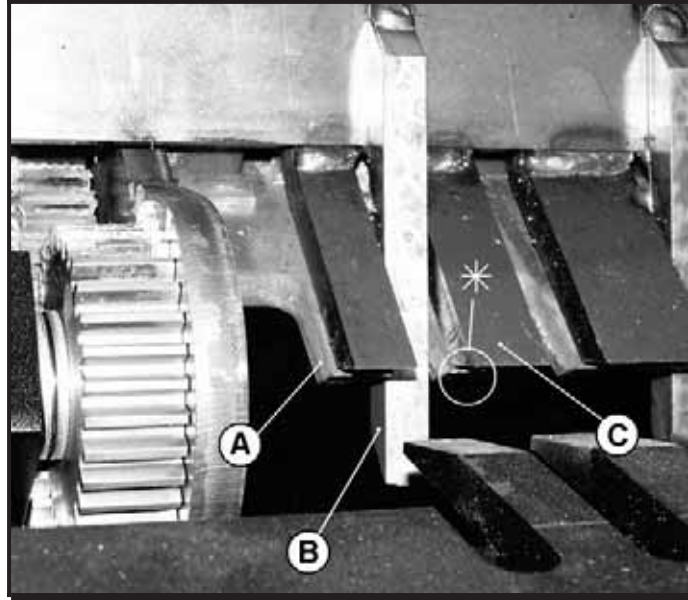

Figure 5-10 Hold Down Bar Adjustment

(1) Adjustment Procedure

1. Loosen both of the Clamp Bolts (Item C).
2. Loosen the lock bolt (Item B) and the lock nut on the adjustment screw (Item A).
3. With the adjustment screw (Item A), turn either clockwise or counter clockwise to raise or lower the Hold Down Bar.

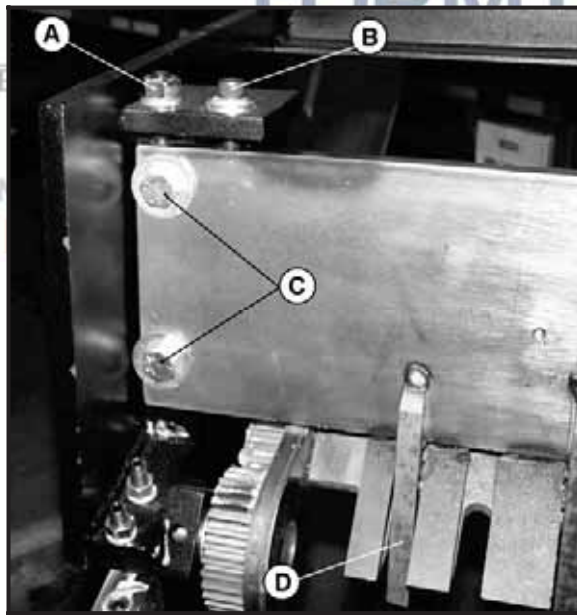

Figure 5-11 Hold Down Bar Adjustment Components

4. Adjust until the surfaces of both bars are flush.
5. Once the bars are flush, use the lock screw (Item B) to secure the Hold Down Bar.

1836 Cleatbender

6. Finally, tighten the lock nut on the adjustment bolt (Item **A**) and retighten the Clamp Bolts (Item **C**).

I. GIB ADJUSTMENT: (ALL 1836 MODELS)

The cam follower at either end of the table will not need adjustment until wear allows the table bar to move excessively. This adjustment was factory set and should require little or no adjustment.

Located underneath the table on each side are cam followers used to reduce play or tightness while the table is traveling. The following is the recommended adjustment procedure.

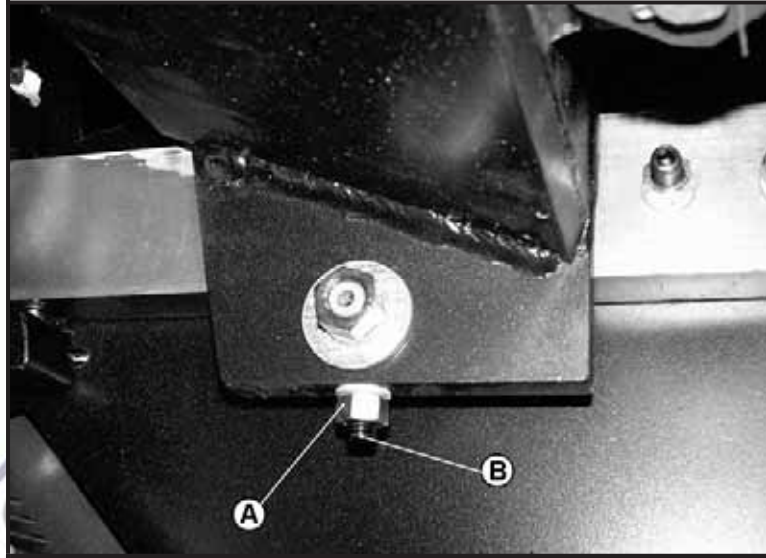

Figure 5-12 Gib Adjustment

1. If excessive play is present, loosen locknut (**A**).
2. Turn setscrew (**B**) until excessive play is removed.
3. Retighten locknut.
4. Recheck that the table operates smoothly and does not bind. IF the table does not move freely, loosen the setscrew an eighth of a turn and recheck.
5. Once the table moves freely without excessive play or is not binding, ensure locknut(s) are secured.

J. BACK GAUGE ADJUSTMENT: (MODELS 1836-1- 3 & 1836-2-3)

The back gauge is moved in and out using the opposing bolts at the rear of the machine.

1836 Cleatbender

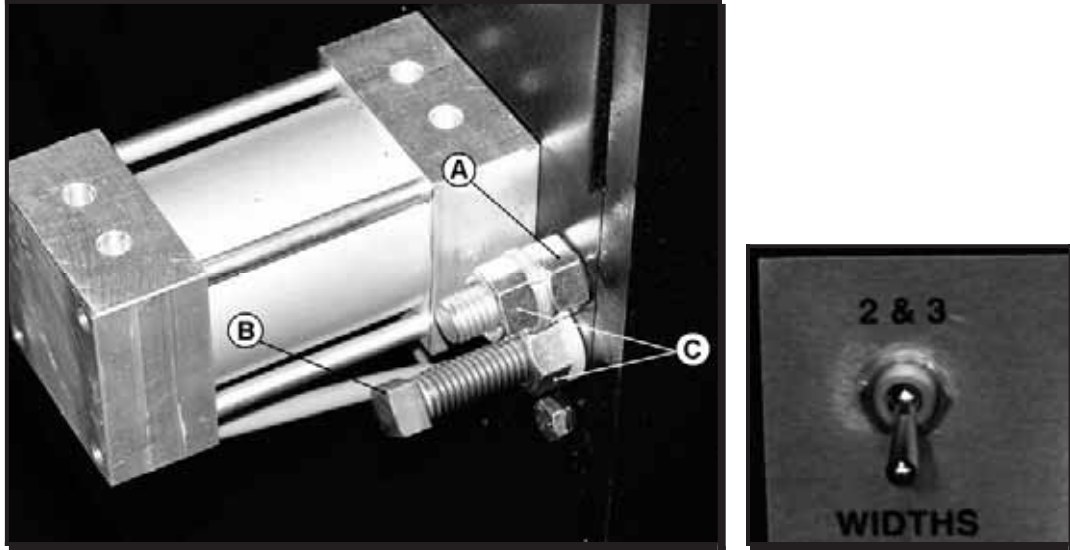

Figure 5-13 Back Gauge Adjustment & Switch Panel

- (1) **Back Gauge Adjustment (1836-1-3):**
 1. Apply air to the unit.
 2. Loosen both locknuts (C).
 3. Use the bottom bolt (B) to push the gage forward and the top inside nut (A) to pull the gauge to the rear.
 4. Tighten both locknuts after adjusting the gauge.
- (2) **Back Gauge Adjustment (1836-2-3):**
 1. Apply air to the unit.
 2. Set the **WIDTHS** toggle switch to the down position.
 3. Loosen both locknuts (C).
 4. To adjust, turn the inside nut (A) on the top to move the gauge in or out for the desired setting.
 5. With the toggle on the switch panel in the up position turn the bottom bolt (B) to move the gauge in or out for the desired setting.
 6. Tighten the locknuts after adjusting the gauge.

K. BACK GAUGE ADJUSTMENT: (MODEL 1836-3-3)

The back gauge is moved in and out using the opposing bolts at the rear corners of the machine.

1836 Cleatbender

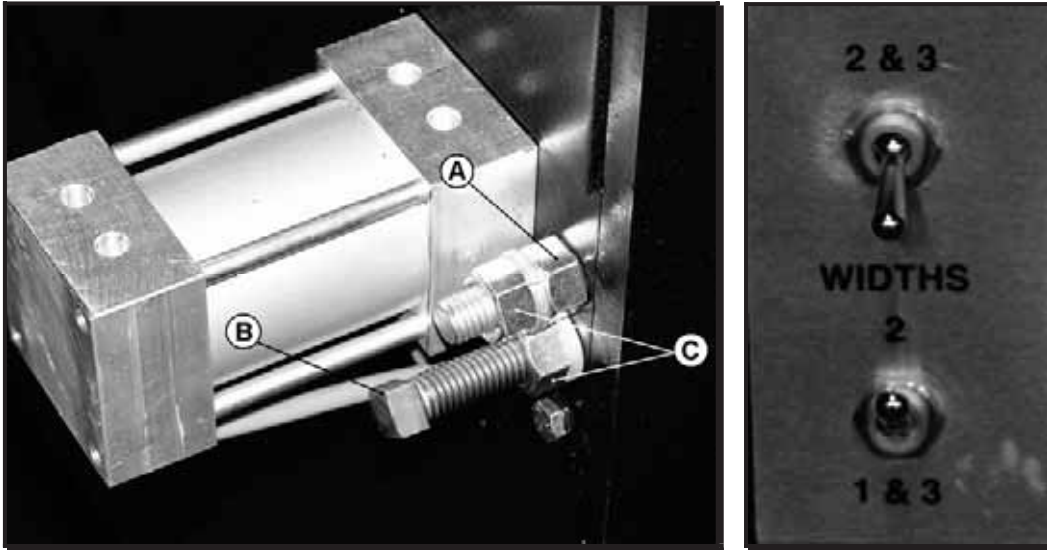

Figure 5-14 Back Gauge Adjustment 1836-3-3

(1) Adjust 1st Back Gauge Position:

1. Apply air to the unit.
2. Set both **WIDTHS** switches are set in the down position.
3. Loosen the locknut (**C**) on bolt (**A**) only.
4. Use the upper bolt (**A**) to adjust the first position.
5. Tighten locknut (**C**) after adjusting the gauge.

(2) Adjust 2nd Back Gauge Position:

1. Apply air to the unit.
2. Set both **WIDTHS** switches to up position.
3. Loosen locknut (**C**) on lower bolt (**B**).
4. Using adjustment bolt (**B**), rotate clockwise to shorten the depth or counter clockwise to lengthen the depth.
5. Tighten the locknut (**C**) after adjusting the gauge and reinstall cover.

(3) Adjust 3rd Back Gauge Position:

1. Apply air to the unit.
2. Set the top **WIDTHS** switch to the up position and the bottom switch to the down position.
3. Remove the cover to access back gauge adjustment.
4. Loosen both locknuts (**A**).
5. Rotate adjustment bolt clockwise to decrease the depth of bend or counter clockwise to increase the depth of bend.
6. Tighten the locknuts (**A**) after adjusting the gauge and reinstall cover.

1836 Cleatbender

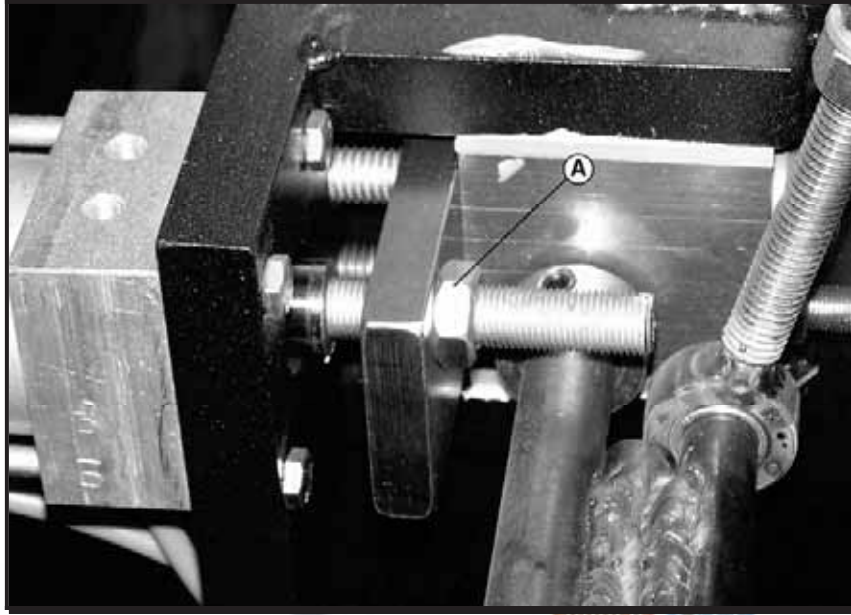

Figure 5-15 Adjusting 3rd Back Gauge Position

L. CLEARING JAMS: (ALL 1836 MODELS)

⚠WARNING!:

Review Safety Instructions before clearing jams.

1. Jams can occur when the operator pushes the work piece into the machine after a bend has been made but before the bending bar returns to the upright position.
 - a. The piece will slide between the bending bar and the hold down bar and get caught.
 - b. The piece may be removed by actuating the bending bar and pulling it out while the bending bar is in motion.
 - c. To actuate the bending bar, press the brass bend push button on the front of the machine.
2. The machine may jam if a double (or greater) thickness of metal is caught between the table bar and the hold down bar.
 - a. In this case the table bar will not travel forward far enough to start the bending cycle.
 - b. To make the table bar pull back, press the table retract push button on the front of the machine.
3. The machine may jam if the bending bar does not travel far enough to complete the bending cycle and locks the piece in the machine.
 - a. This type of jam may be cleared by *disconnecting the air supply hose* and manually bleeding off the air pressure in the machine by depressing the foot pedal until no airflow can be heard. When the pressure drops the bending bar will drop down and the piece may be removed.







⚠NOTICE!:

Do not get "Pittsburgh" edges caught under the fingers of the machine.
Move "Pittsburgh" edges in between the fingers.

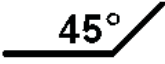
1836 Cleatbender

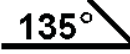
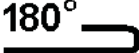
M. BEND CHART

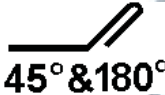
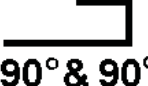
LION metal benders and folders make difficult bends easy on flats, preformed duct, and transition pieces.

	<u>BEND TYPE</u>	<u>DESCRIPTION</u>
	OBTUSE BEND	Activate either of the alternate angle of bend switches on the right side of the front panel, depending upon angle desired.
	RIGHT ANGLE	Top right toggle set from factory at 90° unless otherwise specified.
	ACUTE ANGLE	Activate either of the alternate angle of bend switches on the right side of the front panel, depending upon angle desired.
	DRIVE CLEATS	Switch top left toggle to 2 & 3 position.
	STANDING SEAM	Switch top left toggle to the 2 & 3 position, make bend – activate top right toggle, reinsert metal and make second bend.
	HEMS	Switch top left toggle to the 2 & 3 position, make bend-activate top right toggle, reinsert metal and make second bend.
	DRIP EDGE	Switch top left toggle to 2 & 3 position, make bend-activate bottom right toggle, reinsert metal and make second bend.
	CHANNEL	Top right toggle set from factory at 90°, insert metal make one bend, reinsert metal and make second bend.
	S-CLEATS	Switch top left toggle to 2 & 3 position plus 1 st and 2 nd back gauge position must be used and adjust approximately 1/32" deep to accommodate cleat edge for second bend.
	CORNER LOCK	Depending upon which way the locks are needed, use 2 Hems or 2 Standing Seams and connect.

▲NOTICE!:

Clamping gap may require adjustment depending on material thickness.

SETTINGS

Right Panel	#1=180°	#2=90°	#3=45°
Left Panel	#1=1.000 Inches	#2=.438	#3=.750

1836 Cleatbender

6. Maintenance Instructions: (all 1836 models)

⚠WARNING!

Do not remove guards or covers from the machine unless air supply is disconnected and air pressure has been released from all cylinders and valves. To bleed off the air pressure, depress the BEND START and TABLE RETRACT push buttons several times.

1. Drain water from the compressed air filter (C) at the start of work each day.
2. Ensure air regulator (B) is set at 90psi.
3. Set air lubricator (A) to deliver one (1) drop of oil for each ten (10) machine cycles using pneumatic tool oil.

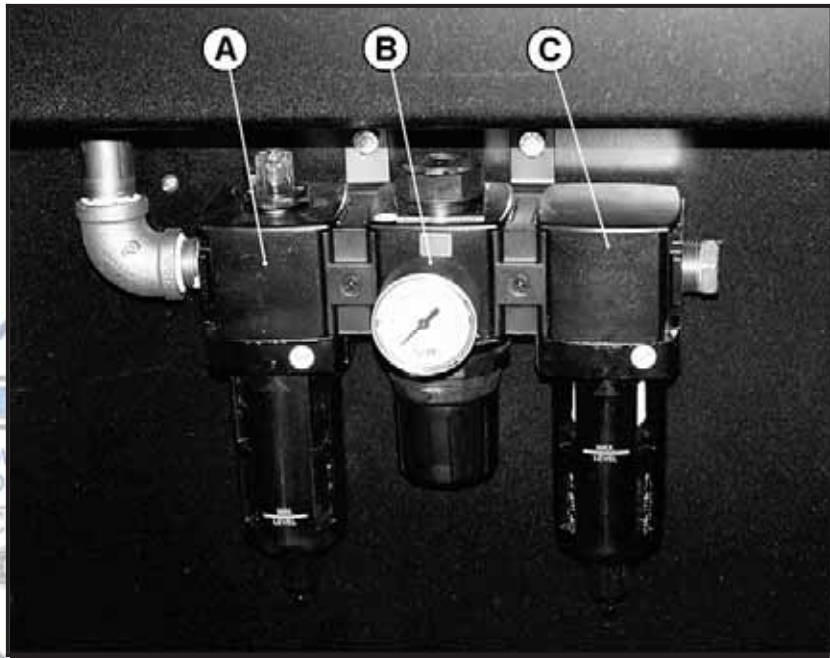

Figure 6-1 Air Filter/Regulator/Lubricator

4. Every three (3) months remove air supply and bleed air pressure from cylinders and valves. Remove the top cover and table.
5. Wipe any dirt and grime from the table guide bars, the gears and the gear racks. Apply a light coat of white lithium grease to the table bar gibs on the top and bottom of the table guide bar.

1836 Cleatbender

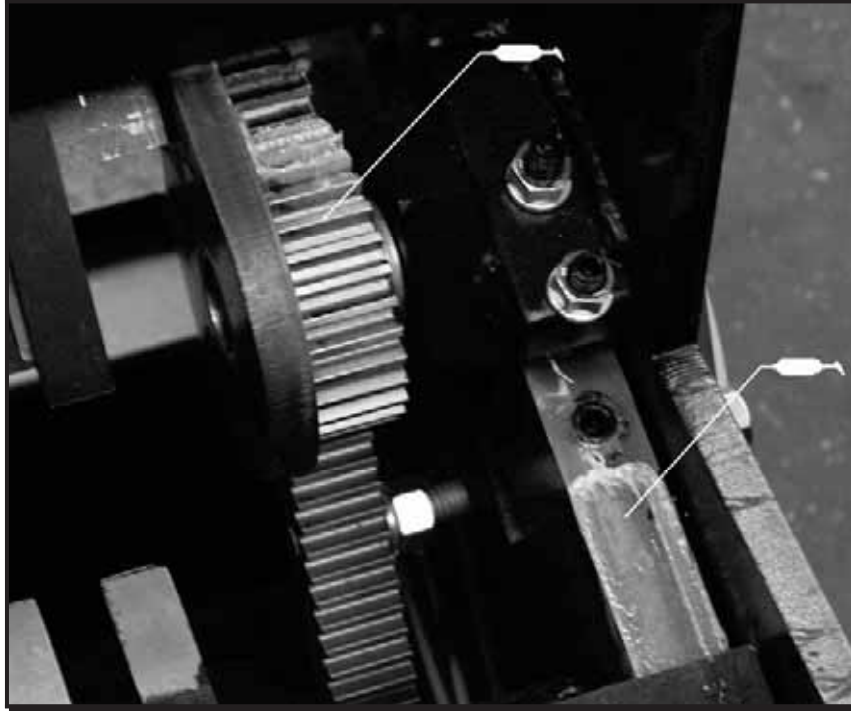

Figure 6-2 Lubrication Points

6. Oil the bending bar pins by dropping oil between the gears and the bearing blocks on the inside of the machine.
7. On models with more than one back gauge position, place a drop of oil on the back gauge shaft at the bronze bushings on either side of the machine. Also oil the return strap at the point where it contacts the cam bar support on the right hand side of the machine.
8. Apply a light coat of white lithium grease on each gear and rack. Put a drop of oil on each pivot pin in the table linkage mechanism. Oil all the points where the linkage members contact each other.
9. The speed controls have sintered metal filters to act as exhaust silencers and to prevent dirt from being drawn into the hoses and cylinders. Do not try to operate the machine without the speed controls and silencers in place. The sintered metal exhaust silencers will become dirty over a period of time and the speed controls will have to be adjusted to allow for proper machine operation. If the silencers get completely plugged they should be replaced.
10. All air components are standard and available from many suppliers across the country. Seal kits for cylinders, O-rings for valves and all air controls and machine parts are available from LION Machinery through your local machinery dealer.

Lion equipment is fully warranted. All parts and labor are guaranteed for a period of thirty days from the date of purchase. In addition, any parts found to be defective within two years of the date of purchase will be exchanged. NO warranty will be in effect if breakage is caused by customer or dealer negligence.

1836 Cleatbender

ASSEMBLY DRAWING LIST

The following listed drawings are included in this manual. If replacement drawings are required, order by drawing number.

DRAWING NO.	TITLE
CF1836-0	1836-0 CLEAT FOLDER ASSEMBLY
1838B-0 SCHEM	VALVE & PIPING SCHEMATIC FOR 1836-0-REVISED
1836B-X-3SCHEM	VALVE & PIPING SCHEMATIC FOR 1836-X-3-REVISED

